

MITSUBISHI MOTORS
GENUINE PARTS

LANCER SIDE WIND DEFLECTOR MZ562863EX INSTALLATION AND HANDLING INSTRUCTIONS

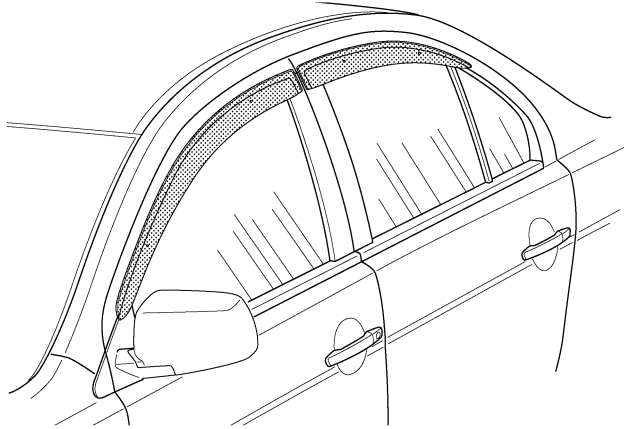

Thank you for purchasing the Mitsubishi Genuine Accessory.
To install and use the product correctly with proper knowledge of it, read this publication carefully.
Keep this publication for reference when maintenance is required.

Attention

- This publication gives precautionary instructions in the boxes titled as follows.
Read through these instructions thoroughly.



Caution

Describes precautions that should be observed in order to prevent injury or damage to the vehicle or its components, which may occur if sufficient care is not taken.



Note

Provides additional information that facilitates installation work.

- Failure to follow these instructions not only prevents the product from working properly but may lead to trouble with the vehicle. Be sure to follow all instructions carefully.
- If there is anything unclear about the installation, handling and/or usage of the product, contact your Mitsubishi Motors dealer for clarification.
- Mitsubishi Motors Corporation is not responsible for any defects or difficulties caused by or resulting from the failure to follow given instructions.
- We recommend you to have the installation performed at an authorized Mitsubishi Motors dealer.





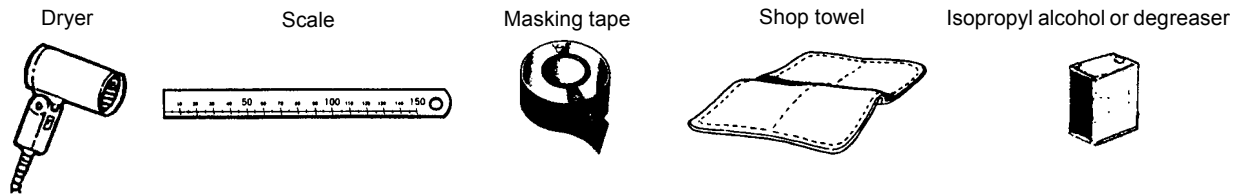

To the dealer:
Be sure that the customer receives this publication.

ZP-57
(06B1544)

■ TOOLS (Make the following tools ready for use.)



■ COMPONENTS (Make sure that all of the following components were included in the kit.)

<p>① Side wind deflector (front, right): 1</p> 	<p>② Side wind deflector (front, left): 1</p> 	
<p>③ Side wind deflector (rear, right): 1</p> 	<p>④ Side wind deflector (rear, left): 1</p> 	<p>⑤ Bracket: 8</p> 
<p>⑥ Push rivet: 8</p> 	<p>⑦ Rivet cap: 8</p> 	

■ PRECAUTIONS

- Be sure to apply the parking brake securely. Remove the ignition key from the key cylinder.
- Adhesive tape loses much of its adhesion if the adhesive surface is touched by a dirty hand or glove, or if the tape is removed after application. If the adhesion is reduced, replace the adhesive tape or the like, otherwise the product may fall off while driving or rainwater may leak.
- Low ambient temperature (below 15°C) greatly reduces the adhesion of adhesive tape and can cause it to peel off. Work in a warm place or warm the surface where the tape is to be applied as necessary.
- The drawings in the Installation Procedures depict the installation of the left side parts. Install the right side parts in the same manner.

INSTALLATION PROCEDURES

A. PREPARATORY WORK

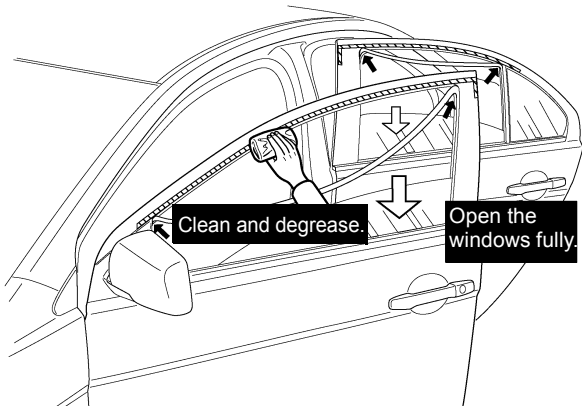

- 1) Open the doors and fully open the door windows.
- 2) Pull off the upper parts of the weatherstrips from the door panels as shown in the drawing.

Note

Never release the corner sections of the weatherstrip (marked by ←). Doing so makes it difficult to reinstall the weatherstrip.

- 3) Clean and degrease the deflector mounting surfaces (hatched area on the door panel) with a shop towel dampened with isopropyl alcohol or degreaser, and then dry the surface with a dryer.

Caution

- Perform this work in a well-ventilated area. Keep away from flames.
- Never use organic solvent such as thinner, benzine and gasoline.
- Be sure to degrease completely. Otherwise, the deflector may come off or rainwater may leak.

Check

B. POSITIONING THE DEFLECTORS

- 1) Apply four pieces of masking tape at the positions shown in the drawing.

Note

Be sure to attach them to the correct positions as they are used as references for positioning the deflectors.

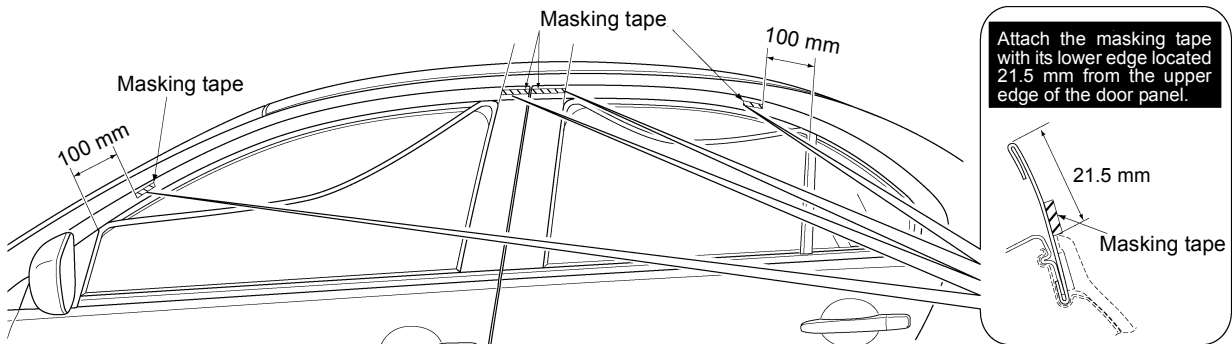

Attach the masking tape with its lower edge located 21.5 mm from the upper edge of the door panel.

Check

C. INSTALLING BRACKETS TO THE DEFLECTORS

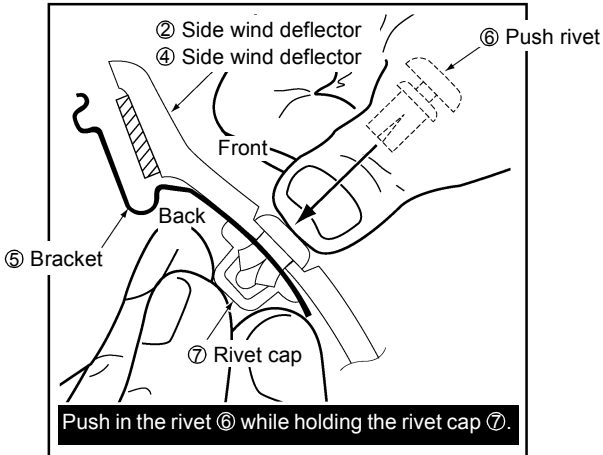

Cross-sectional view of the push rivet mounting section

- 1) Install the brackets ⑤ at the back of the side wind deflectors ② and ④. Place the bracket ⑤ and rivet cap ⑦ at the back of each mounting hole and press in the push rivet ⑥ from the front side. Refer to the cross-sectional view of the push rivet mounting section.

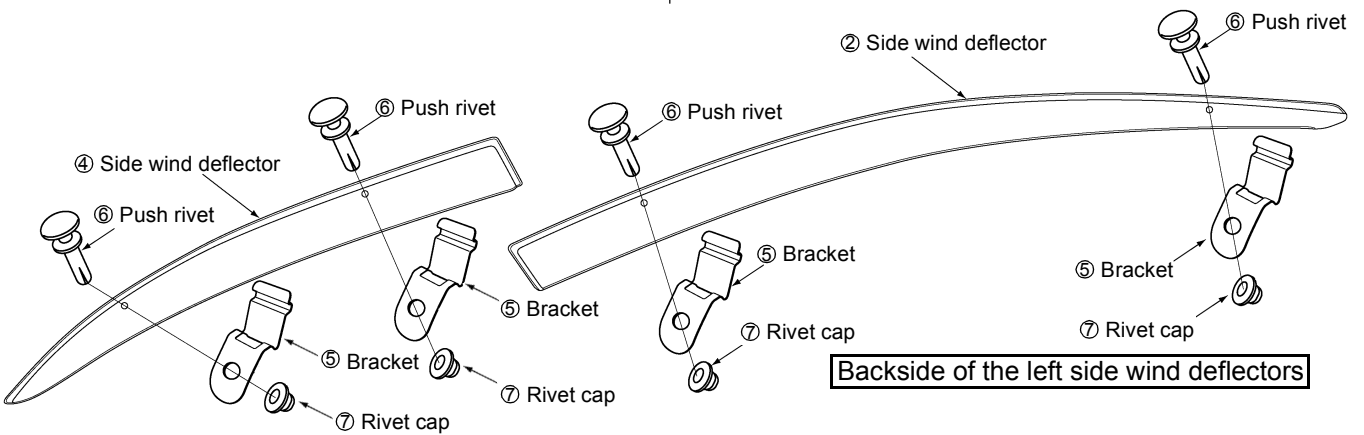

Check	
-------	--

D. INSTALLING THE SIDE WIND DEFLECTORS

- 1) Peel back each end of the backing strip at the back of the side wind deflectors ② and ④ by approx. 30 mm, and bend these ends outward.

Note

If bent inward, the backing strip will be caught by the bracket ⑤ when peeling off, and then cannot be peeled off completely.

Peel off the backing strip by approx. 30 mm.

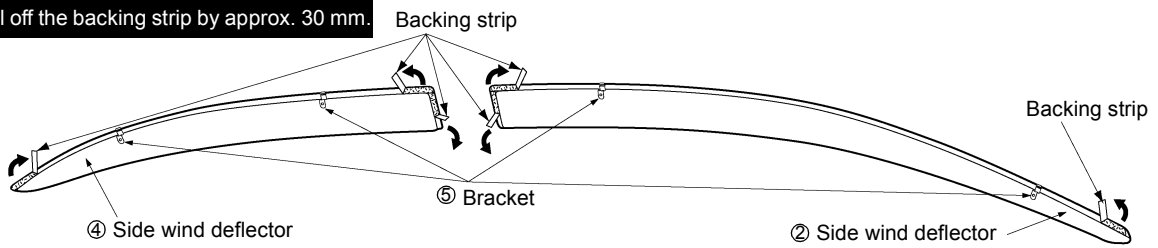

Backside of the left side wind deflectors

- 2) Install the side wind deflector ② as follows:
 - (1) Align the upper edge of the deflector ② with the lower edges of the masking tapes.
 - (2) Push in the brackets ⑤ until they contact the lower edge of the door panel as shown in the drawing.

⚠ Caution

Insert the brackets securely behind the door panel.

- (3) Position the rear end of the deflector ② 1 mm away from the rear edge of the front door panel.

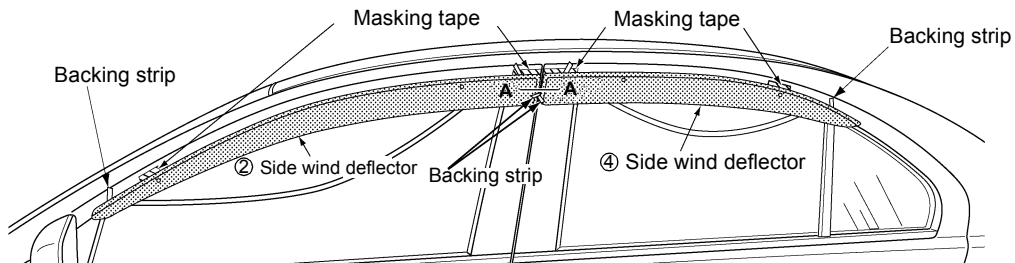

Push the bracket ⑤ until it seats fully on the lower edge of the door panel.

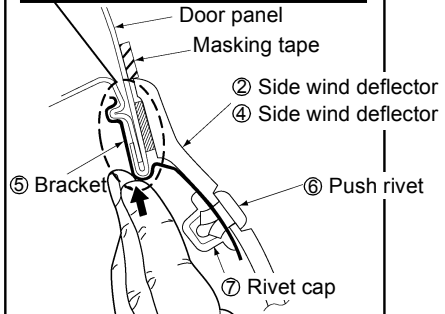

Sectional view of bracket mounting section

Position the deflectors 1 mm inward from the edge of the front and rear door panels respectively.

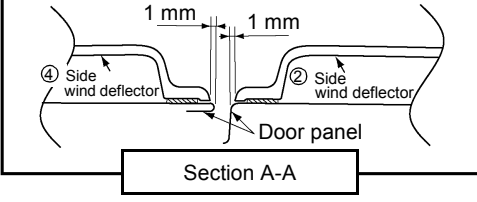

Section A-A

- 3) Install the side window deflector ④ in the same way except that the front end of the deflector ④ should be positioned 1 mm inside from the front edge of the rear door panel.
- 4) Peel off the masking tape.
- 5) Confirm that the side deflectors are attached to the correct positions.
- 6) Pull each end of the backing strip slowly in the arrow direction (←) to remove it completely.

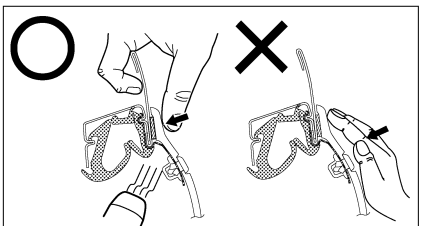
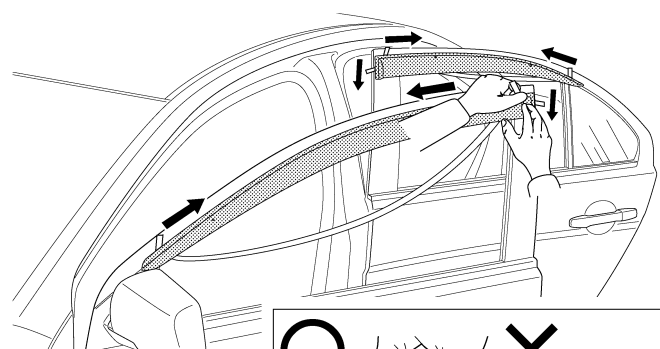

Sectional view of the deflector mounting section

7) While heating the adhesive tape attaching surface to approx. 40°C (heat the place for approx. 30 seconds), press the adhesive tape and attach it firmly.



Caution

Be careful not to get burnt.



Note

Press the deflector firmly such that the vehicle shakes a little.

Check

E. REINSTALLING THE WEATHERSTRIP

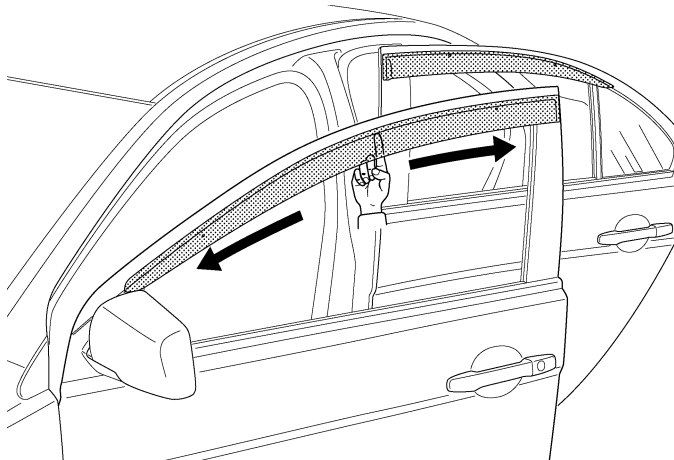

1) Reinstall the released weatherstrip. Make sure that it is mounted correctly in position, especially at the bracket mounting portions.



Note

Fit the weatherstrip securely into position with your finger. If it is mounted incorrectly, it may be caught or deformed when the window is closed.

Door panel

- ② Side wind deflector
- ④ Side wind deflector

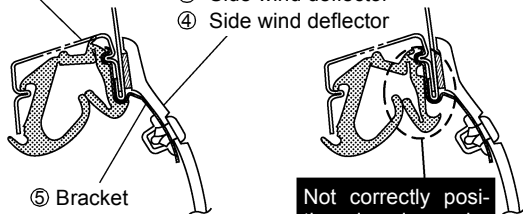

⑤ Bracket

Not correctly positioned and may be caught by the window glass.



Sectional view of the bracket mounting section

Check

F. CHECKING AFTER INSTALLATION

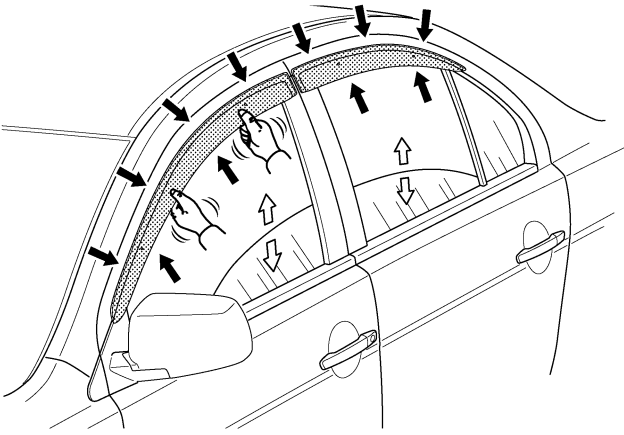

- 1) Look in the arrow directions and check that there is no gap between the deflector and the door panel.
- 2) Pull the deflector lightly to check it is attached securely.
- 3) Open and close the window several times to check that the window moves smoothly and the weather-strip is not caught by the window glass.



Caution

Do not wash the vehicle for 24 hours after attaching the product to prevent it from peeling off. Keep the vehicle away from water during this period.

Check	
-------	--

CARE AND HANDLING

- This product is made of acrylic resin. Do not apply excessive force on the product, as this may deform or damage it.
- To clean the product, wash with water and then wipe using a soft cloth moistened with neutral detergent.
- Take care to prevent contact with gasoline, kerosene, brake fluid, engine oil, grease, paint thinner, sulfuric acid (battery electrolyte) and wax remover that could cause discoloration, staining and cracking. Should any of them contact the surface, remove the substance immediately by wiping with a soft cloth or chamois leather moistened with a mild detergent, then wash the surface completely with water.
- Do not use wax. It could scratch the surface and fog the product.