

MITSUBISHI MOTORS  
GENUINE PARTS

# OUTLANDER SIDE MOULDING MZ538302EX (GRAY) INSTALLATION AND HANDLING INSTRUCTIONS

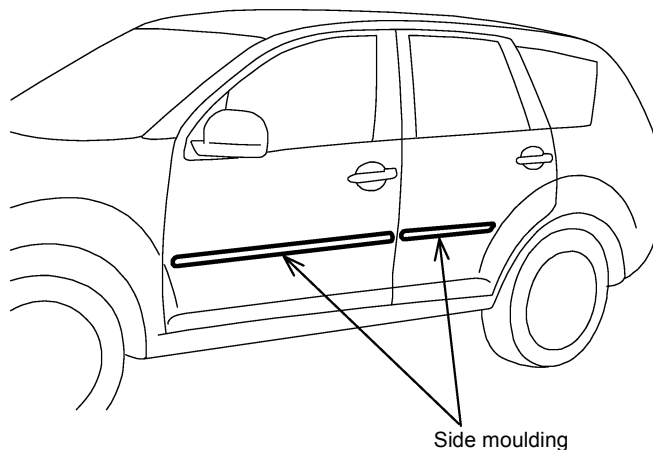

Thank you for purchasing the Mitsubishi Genuine Accessory.  
To install and use the product correctly with proper knowledge of it, read this publication carefully.  
Keep this publication for reference when maintenance is required.

## Attention

- This publication gives precautionary instructions in the boxes titled as follows.  
Read through these instructions thoroughly.

 **Caution** Describes precautions that should be observed in order to prevent injury or damage to the vehicle or its components, which may occur if sufficient care is not taken.

 **Note** Provides additional information that facilitates installation work.

- Failure to follow these instructions not only prevents the product from working properly but may lead to trouble with the vehicle. Be sure to follow all instructions carefully.
- If there is anything unclear about the installation, handling and/or usage of the product, contact your Mitsubishi Motors dealer for clarification.
- Mitsubishi Motors Corporation is not responsible for any defects or difficulties caused by or resulting from the failure to follow given instructions.
- We recommend you to have the installation performed at an authorized Mitsubishi Motors dealer.

To the dealer:  
Be sure that the customer receives this publication.

■ **TOOLS** (Make the following tools ready for use.)

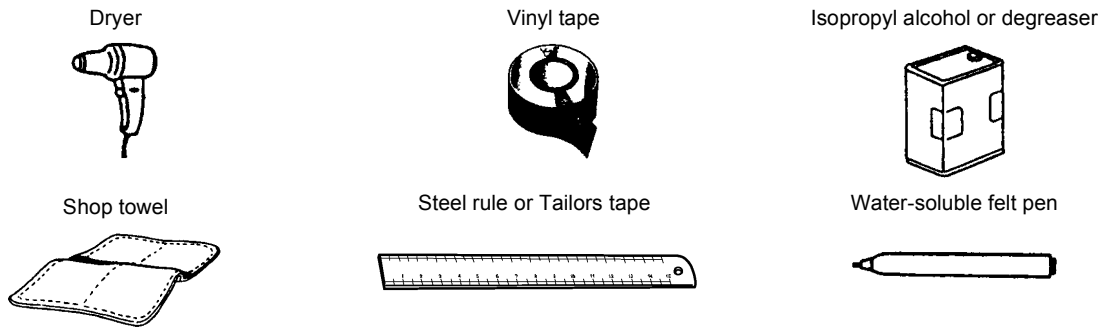

■ **COMPONENTS** (Make sure that all of the following components were included in the kit.)

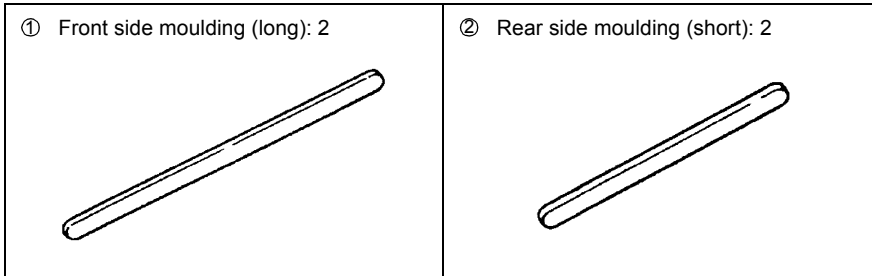

■ **PRECAUTIONS**

- Be sure to apply the parking brake securely. Remove the ignition key from the key cylinder.
- Be sure to handle the side moulding with both hands to prevent it from bending. Otherwise, wrinkles or cracks may occur on the painted surface of the moulding.
- Do not discard the cardboard (separator) contained in the carton of the side mouldings as it is used for installation.
- Be sure to wipe off dust and oil from the surfaces where adhesive tape is to be attached using a clean shop towel moistened with isopropyl alcohol or degreaser. Never use organic solvent such as thinner, benzine, gasoline, etc.
- Adhesive tape loses much of its adhesive strength if its surface is touched by a dirty hand or glove, or if the tape is removed after application. If the adhesion is reduced, take appropriate remedies such as replacing the adhesive tape, otherwise the product may fall off while driving.
- Low ambient temperature (below 15°C) greatly reduces the adhesive strength of adhesive tape, which can cause peeling off. Work in a warm place or warm the surface where tape is to be attached as necessary.
- The illustrations in the Installation Procedures depict the installation of the left side part. Install the other parts in the same manner.

# INSTALLATION PROCEDURES

## A. INSTALLING THE FRONT SIDE MOULDING

Vehicles without door garnishes

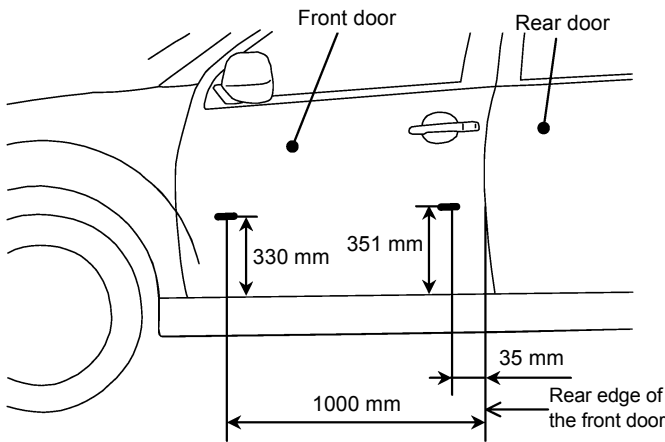

- 1) Mark the two positions shown in the drawing with the water-soluble felt pen.

### Note

Measure the distance as shown using a tape measure.

Vehicles without door garnishes

Measure from the bottom edge of the door.

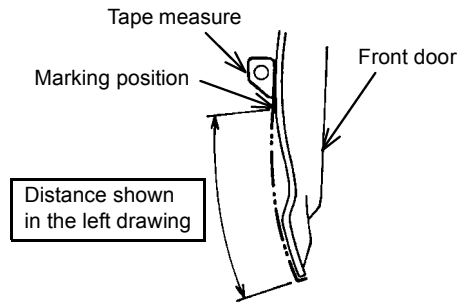

- Hold tape or rule on back side of the 1000 mm mark to measure up to 330 mm.
- Hold tape or rule on either side of 35 mm mark to measure up to 351 mm.

### Note

The following steps are common to vehicles with and without door garnishes.

- 2) Wipe clean and degrease the surface to attach the front side moulding ① (hatched portion in the drawing) using a clean shop towel moistened with isopropyl alcohol or degreaser.

### Caution

Perform this work in a well-ventilated area. Keep away from flames.

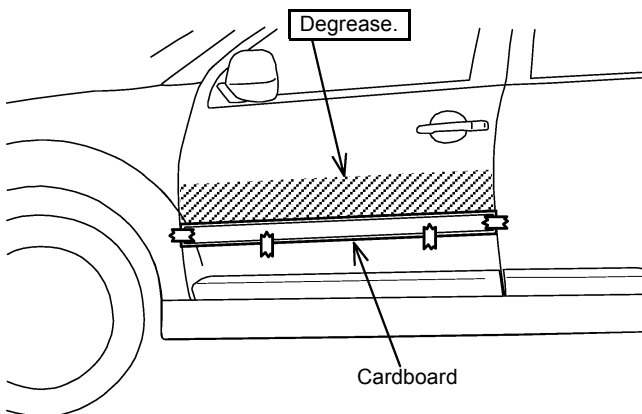

Vehicles without door garnishes

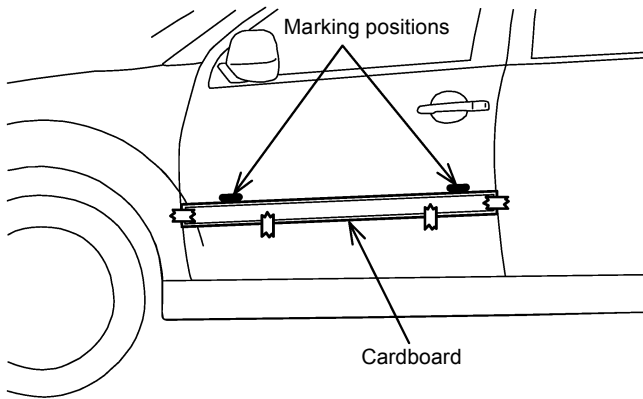

Peel off the backing strip to approx. 30 mm.

① Front side moulding

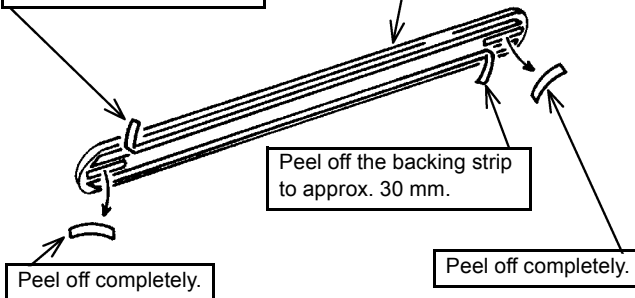

① Front side moulding

Place along the upper edge of the cardboard.

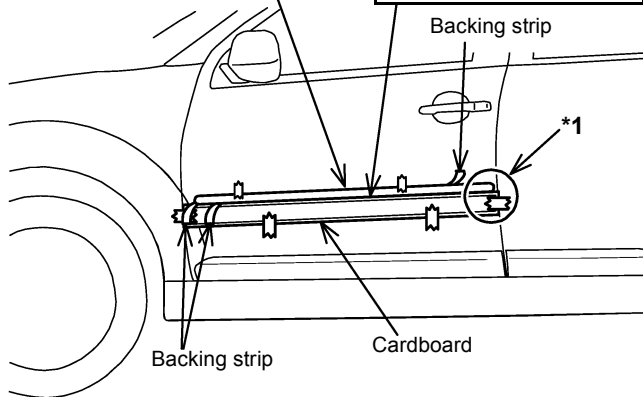

- Use the cardboard contained in the carton of the side mouldings. Align the upper edge of the cardboard with the markings as shown in the drawing and fix it with vinyl tape.

**Caution**

- Fix the cardboard securely so that it does not float or move out of position.
- Do not attach vinyl tape at the upper side of the cardboard.

- Peel off one end of each of the two longer backing strips at the backside of the front side moulding ① to approximately 30 mm and fold the end outward. Peel off the two shorter backing strips completely.

- Place the front side moulding ① along the upper edge of the cardboard. Position the rear end of the moulding at the point 15 mm from the rear edge of the front door and temporarily fix the moulding with vinyl tape.

- Slightly lift up the adhesive tape sections of the front side moulding ① and peel off the backing-strips. Be careful not to bend the front side moulding ①.

**Caution**

- Peel off the backing-strips from one end to the other, not from both ends to the middle.

\*1

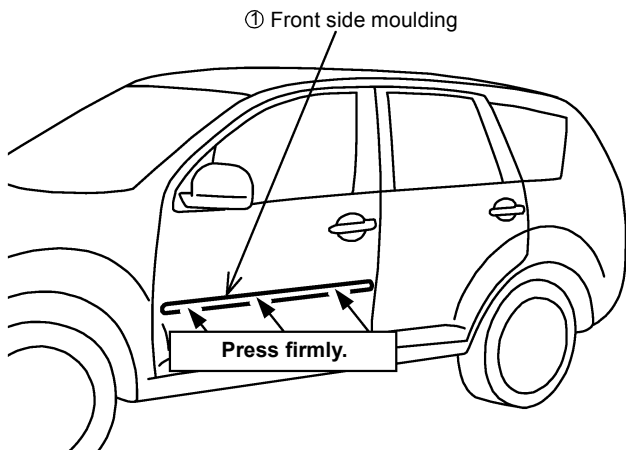
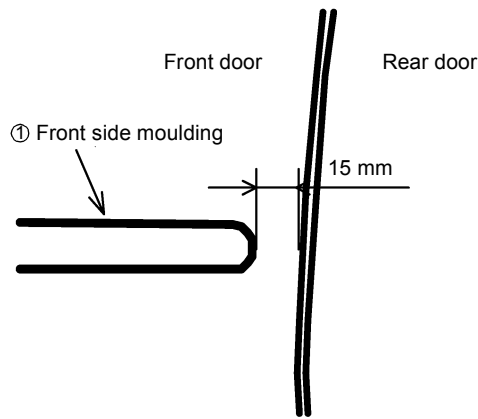

7) Press the adhesive tape portions of the front side moulding ① firmly. Remove the cardboard.

|       |  |
|-------|--|
| Check |  |
|-------|--|

## B. INSTALLING THE REAR SIDE MOULDING

Vehicles without door garnishes

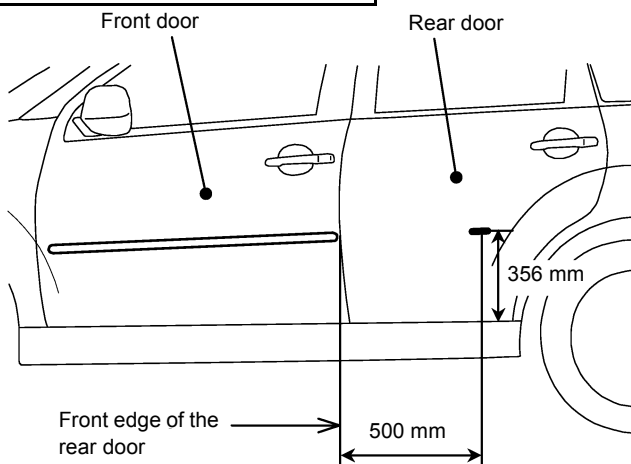

1) Mark the one positions shown in the drawing with the water-soluble felt pen for reference only.

### Note

Measure the distance as shown using a tape measure.

Vehicles without door garnishes

Measure from the bottom edge of the door.

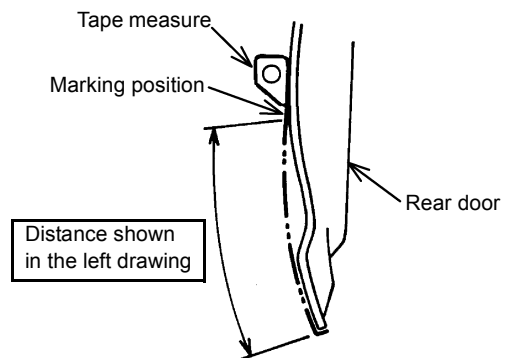

Hold tape or rule on back side of the 500 mm mark to measure up to 356 mm.

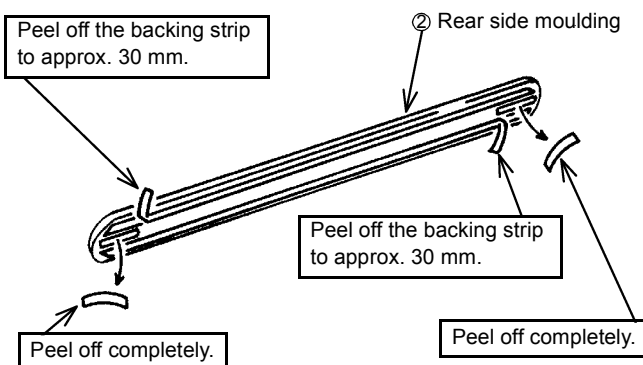
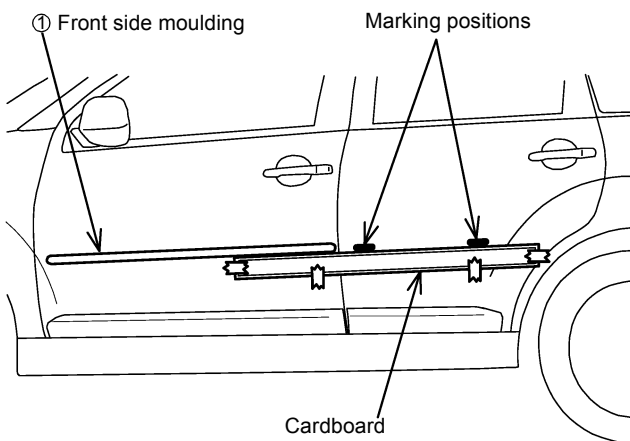
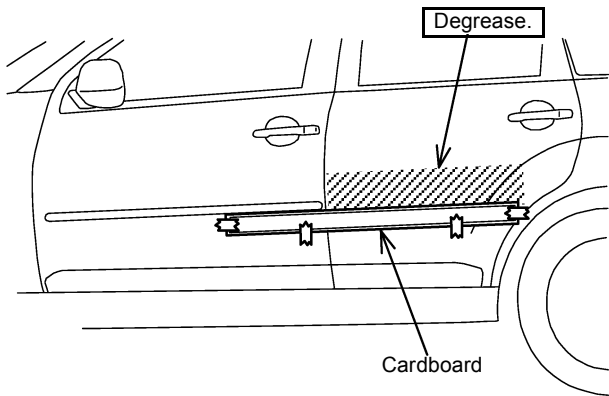

- 2) Wipe clean and degrease the surface to attach the rear side moulding ② (hatched portion in the drawing) using a clean shop towel moistened with isopropyl alcohol or degreaser.



### Caution

Perform this work in a well-ventilated area. Keep away from flames.



### Note

The following steps are common to vehicles with and without door garnishes.

- 3) Align the upper edge of the cardboard with the bottom of the front side moulding ① and the two markings as shown in the drawing, and fix the cardboard with vinyl tape.



### Caution

- Fix the cardboard securely so that it does not float or move out of position.
- Use the marked position for reference only make sure to align with front door moulding.
- Do not attach vinyl tape at the upper side of the cardboard.

- 4) Peel off one end of each of the two longer backing strips at the backside of the rear side moulding ② to approximately 30 mm and fold the end outward. Peel off the two shorter backing strips completely.

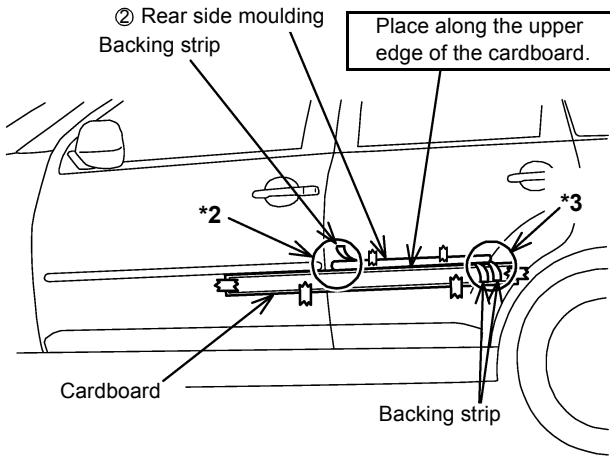

5) Place the rear side moulding ② along the upper edge of the cardboard. Position the front end of the moulding at the point 10 mm from the front edge of the rear door and temporarily fix the moulding with vinyl tape.

6) Slightly lift up the adhesive tape sections of the rear side moulding ② and peel off the backing strips. Be careful not to bend the rear side moulding ②.

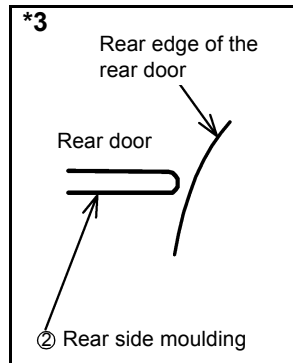
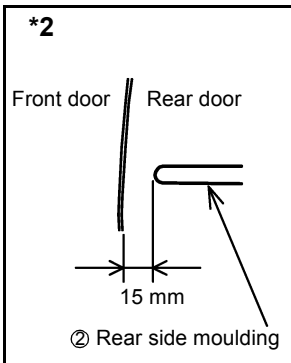

7) Press the adhesive tape portions of the rear side moulding ② firmly. Remove the cardboard.

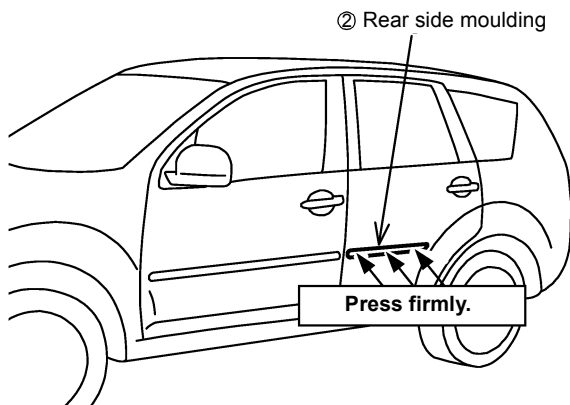

|       |                          |
|-------|--------------------------|
| Check | <input type="checkbox"/> |
|-------|--------------------------|

### C. CHECKING AFTER INSTALLATION

- Check the installation condition of the product.
- Check that all the adhesive tapes are attached securely.



#### Caution

- Do not wash the vehicle for 24 hours after attaching the product otherwise it may peel off. Even if washing or waxing is necessary, wait at least 6 hours. Keep the vehicle out of the rain during this period.

|       |                          |
|-------|--------------------------|
| Check | <input type="checkbox"/> |
|-------|--------------------------|

### CARE AND HANDLING

- To clean the product, wipe with a soft material such as sponge or chamois leather.
- Do not use any hard material for cleaning such as a scrubbing brush, as it could scratch the surface.
- Do not use wax with compound, as it could damage the surface.
- Take care to prevent contact with gasoline, kerosene, brake fluid, engine oil, grease, paint thinner, sulfuric acid (battery electrolyte) and wax remover that could cause discoloration, staining and cracking. Should any of them contact the surface, remove the substance immediately by wiping with a soft cloth or chamois leather moistened with mild detergent, then wash the surface thoroughly with water.