

LANCER SCUFF PLATE MZ380402EX INSTALLATION AND HANDLING INSTRUCTIONS

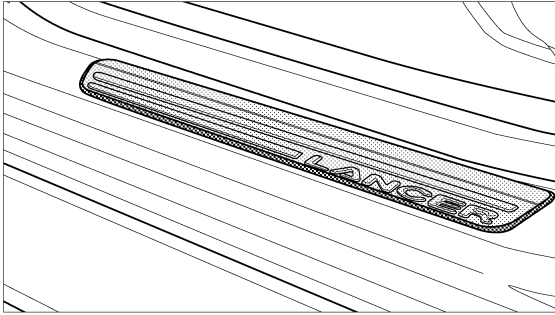

Front (left)

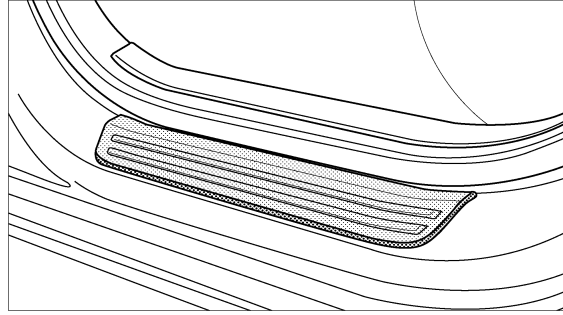

Rear (left)

Thank you for purchasing the Mitsubishi Genuine Accessory.
To install and use the product correctly with proper knowledge of it, read this publication carefully.
Keep this publication for reference when maintenance is required.

Attention

- This publication gives precautionary instructions in the boxes titled as follows.
Read through these instructions thoroughly.



Caution

Describes precautions that should be observed in order to prevent injury or damage to the vehicle or its components, which may occur if sufficient care is not taken.



Note

Provides additional information that facilitates installation work.

- Failure to follow these instructions not only prevents the product from working properly but may lead to trouble with the vehicle. Be sure to follow all instructions carefully.
- If there is anything unclear about the installation, handling and/or usage of the product, contact your Mitsubishi Motors dealer for clarification.
- Mitsubishi Motors Corporation is not responsible for any defects or difficulties caused by or resulting from the failure to follow given instructions.
- We recommend you to have the installation performed at an authorized Mitsubishi Motors dealer.

To the dealer:

Be sure that the customer receives this publication.

■ **TOOLS** (Make the following tools ready for use.)

Isopropyl alcohol or degrease

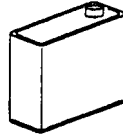

Shop towel

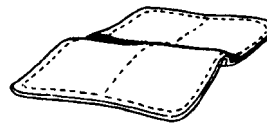

■ **COMPONENTS** (Make sure that all of the following components were included in the kit.)

① Front scuff plate, left: 1

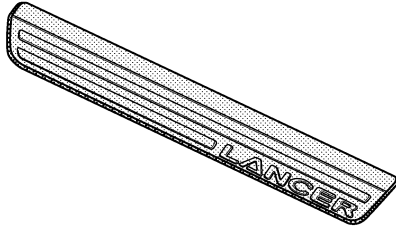

② Front scuff plate, right: 1

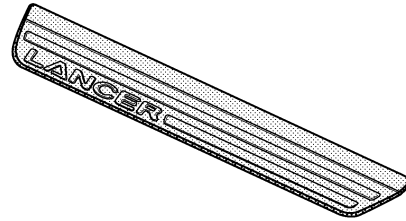

③ Rear scuff plate, left: 1

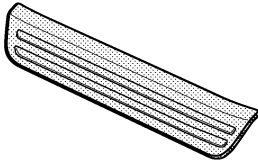

④ Rear scuff plate, right: 1

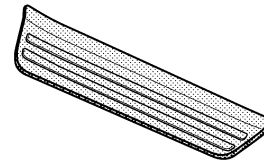

Direction of the parts (left-side parts shown)

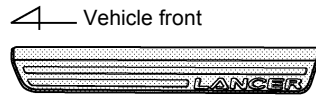

Front

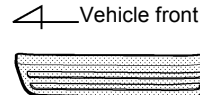

Rear

■ **PRECAUTIONS**

- This product may not be installed together with some other Mitsubishi genuine accessories. Check for compatibility before installing this product.
- Park the vehicle on a flat, horizontal place.
- Be sure to apply the parking brake securely. Remove the ignition key from its key cylinder.
- Be careful not to apply excessive force to the product, as this may deform the product, causing faulty installation.
- Adhesive tape loses much of its adhesion if the adhesive surface is touched by a dirty hand or glove, or if the tape is removed after application. If the adhesion is reduced, replace the adhesive tape or the like, otherwise the product may fall off while driving.
- Low ambient temperature (below 15°C) greatly reduces the adhesion of adhesive tape and can cause it to peel off. Work in a warm place or warm the surface where the tape is to be applied as necessary.
- The drawings in the Installation Procedures mainly depict the installation of the front left side part. Install the other parts in the same manner.

INSTALLATION PROCEDURES

A. ATTACHING THE SCUFF PLATE

1) Wipe clean and degrease the shaded section shown in the drawing using isopropyl alcohol or degreaser.

⚠ Caution

- Never use paint thinner, benzene, gasoline, or other organic solvent for this purpose.
- If degreasing is not performed, the product may come off.

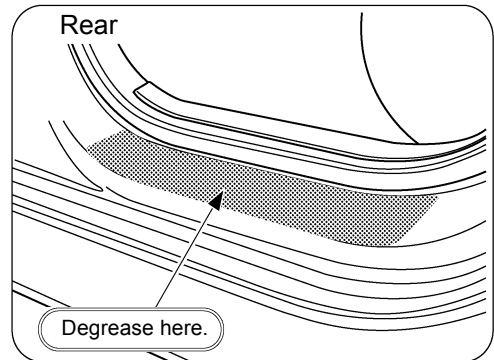
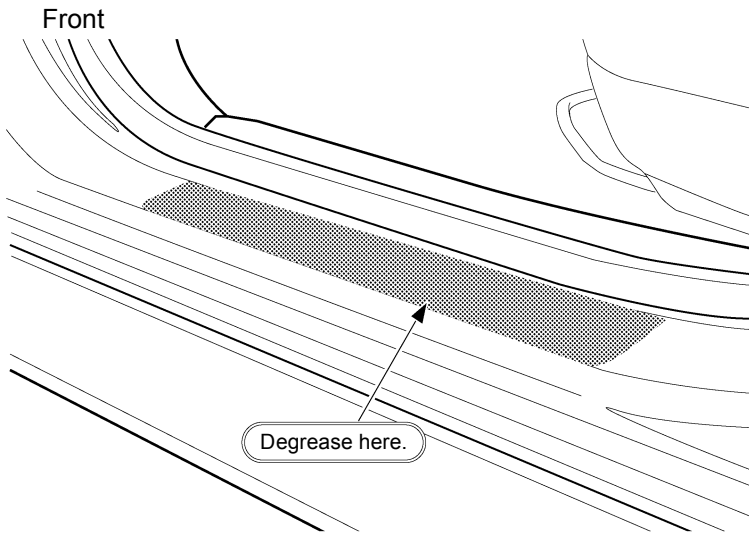

2) Peel the backing strips of the double-sided tapes on the back of the front scuff plate ① partly as shown in the drawing.

📖 Note

Fixing peeled ends of the strips on the upper surface of the front scuff plate ① with adhesive tape will facilitate the following steps.

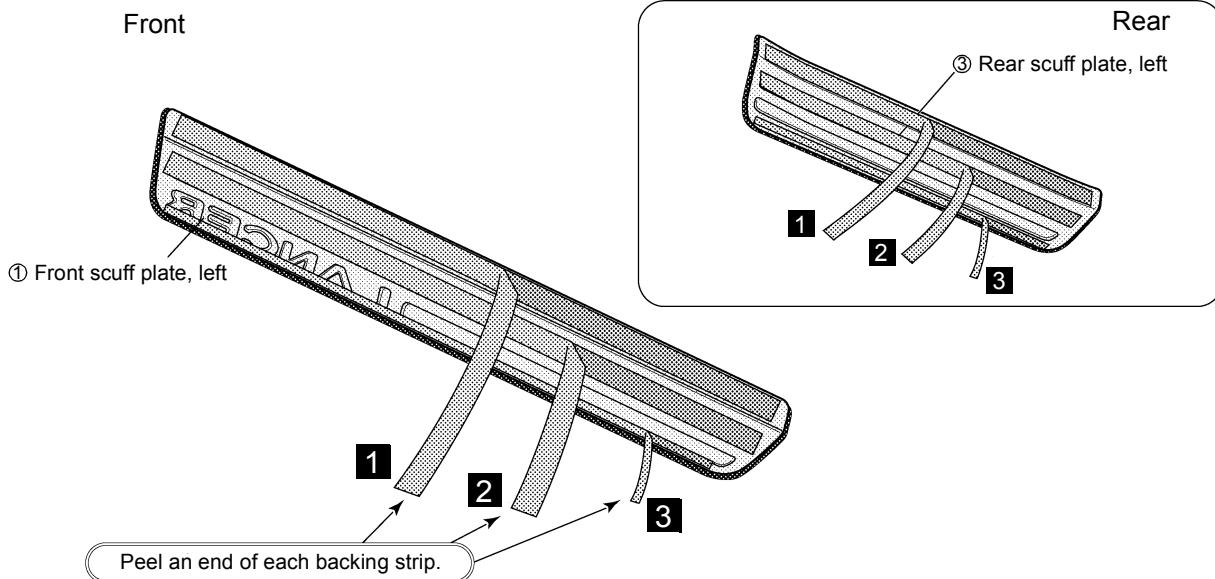

3) Position the front scuff plate ① as shown in the drawing.

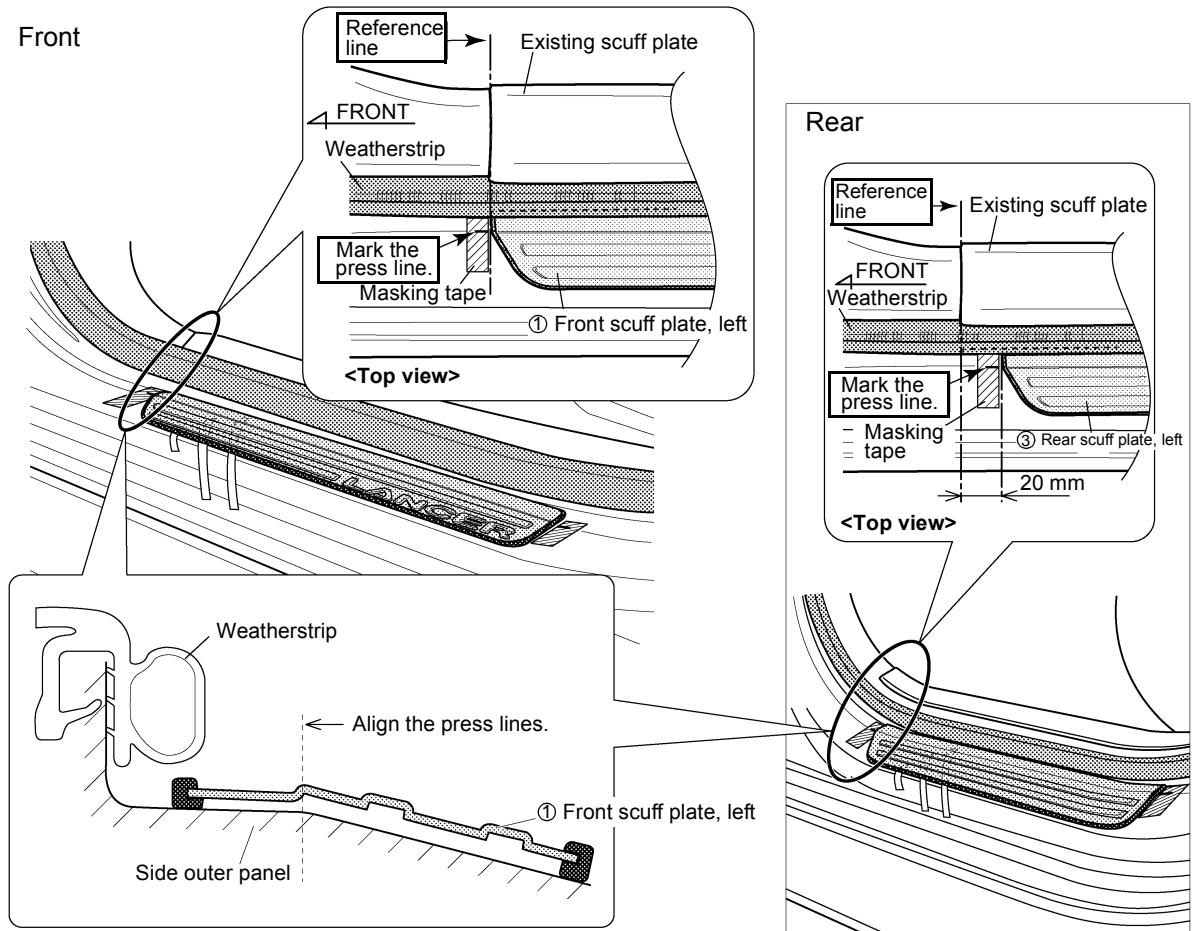

4) Adjust the position of the front scuff plate ① so that it is parallel with the vehicle's existing scuff plate. Then slowly peel off the backing strips in the order of ❶ to ❸. After that, press the front scuff plate ① firmly from the front to the rear to fix it securely.

⚠ Caution

- If the front scuff plate ① is removed after being attached, it may be deformed. Be sure to position the scuff plate carefully.
- Be sure to peel off all the backing strips completely.

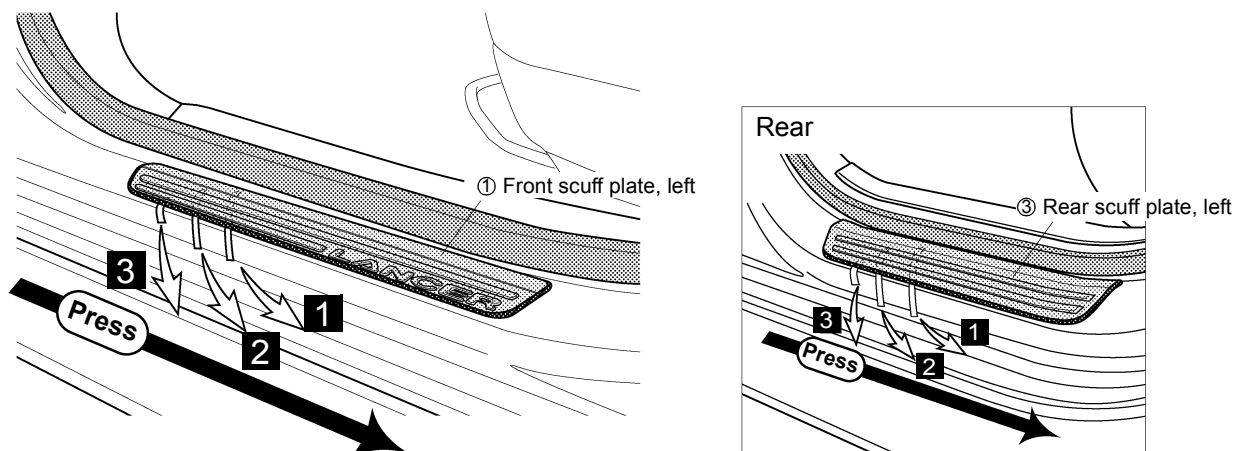

Check

B. CHECKING AFTER INSTALLATION

- Check that the scuff plates are located in the proper positions.
- Check that the worked area on the vehicle body is clean.
- Check that the scuff plates are fitted securely.



Caution

Do not wash the vehicle for 24 hours after attaching the product to prevent it peeling off. Even if washing or waxing is necessary, wait at least 6 hours. Keep the vehicle off the rain during this storage period.

Check	<input type="checkbox"/>
-------	--------------------------

CARE AND HANDLING

- If the product is damaged, repair or replace it immediately.
- Do not apply excessive force on the product, as this may deform or damage it.
- This product is made of stainless steel. To remove dirt on the product, wipe it off using a soft cloth moistened with neutral detergent. Leaving the product dirty may cause the product to rust. Although rust can be removed using wax with compound, this may scratch the surface of the product.