

MITSUBISHI MOTORS
GENUINE PARTS

LANCER REAR MUDGUARD MZ380401EX INSTALLATION AND HANDLING INSTRUCTIONS

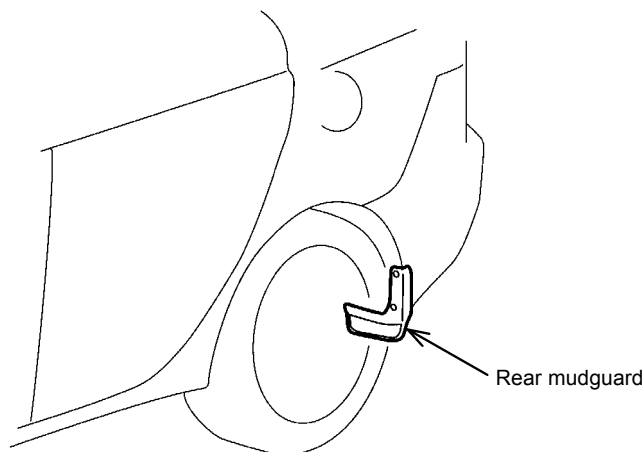

Thank you for purchasing the Mitsubishi Genuine Accessory.
To install and use the product correctly with proper knowledge of it, read this publication carefully.
Keep this publication for reference when maintenance is required.

Attention

- This publication gives precautionary instructions in the boxes titled as follows.
Read through these instructions thoroughly.

⚠ Caution Describes precautions that should be observed in order to prevent injury or damage to the vehicle or its components, which may occur if sufficient care is not taken.

📖 Note Provides additional information that facilitates installation work.

- Failure to follow these instructions not only prevents the product from working properly but may lead to trouble with the vehicle. Be sure to follow all instructions carefully.
- If there is anything unclear about the installation, handling and/or usage of the product, contact your Mitsubishi Motors dealer for clarification.
- Mitsubishi Motors Corporation is not responsible for any defects or difficulties caused by or resulting from the failure to follow given instructions.
- We recommend you to have the installation performed at an authorized Mitsubishi Motors dealer.

To the dealer:
Be sure that the customer receives this publication.

J1261228
(06B1544)

■ **TOOLS** (Make the following tools ready for use.)

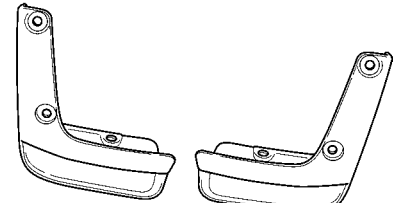
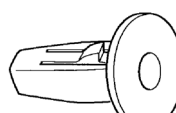
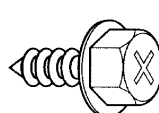
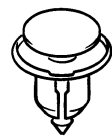
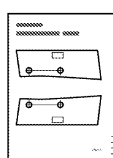

■ **COMPONENTS** (Make sure that all of the following components were included in the kit.)

<p>① Rear mudguard: 2 (right and left, 1 each)</p> 	<p>② Grommet: 4</p> 	<p>③ Tapping screw (6 x 20): 4</p> 
<p>④ Clip: 4</p> 	<p>⑤ Template: 1</p> 	

■ **PRECAUTIONS**

- Perform the work in a well-ventilated space away from flames.
- Be sure to apply the parking brake securely. Remove the ignition key from the key cylinder.
- The drawings in the Installation Procedures depict the installation of the left side parts. Install the right side parts in the same manner.

INSTALLATION PROCEDURES

A. DRILLING ON THE REAR BUMPER

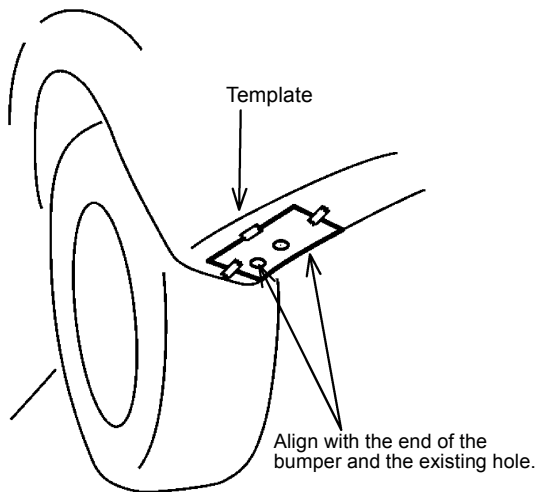
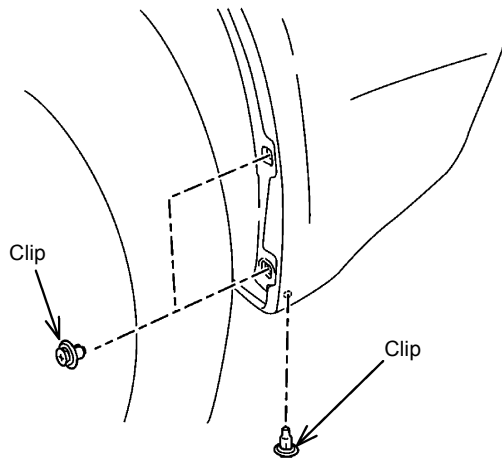
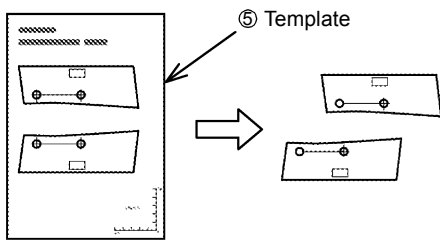

- 1) Cut off the right and left templates from the template ⑤.



Note

Do not confuse the right and left templates.

- 2) Remove the two splash shield mounting clips on the inside of the rear wheelhouse and one clip at the bottom of the bumper.

- 3) With the end of the bumper and the existing hole as references, attach the template on the bumper with vinyl tape.

- 4) Temporarily install the rear mudguard ① correctly in accordance with step B. Make sure that there is no clearance between the rear mudguard and the body, then confirm that a hole under the rear mudguard ① aligns with the drilling hole position on the template.

- 5) Remove the temporarily installed rear mudguard ①. Mark the center of the drilling hole position.

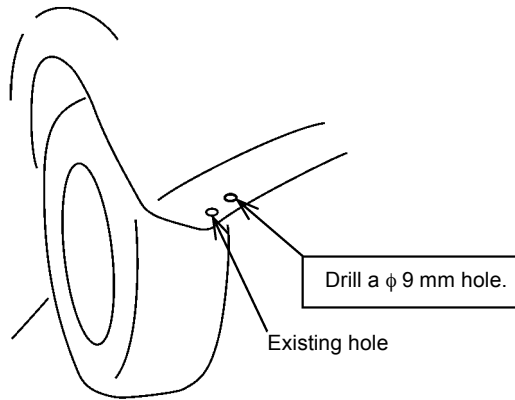

6) Drill a ϕ 3 mm base hole and then a ϕ 9 mm hole.

⚠ Caution

- Before drilling, wrap the drill bit tightly with vinyl tape to prevent it from damaging the other parts.

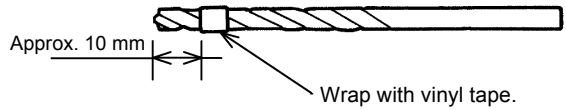

- When drilling, always wear safety goggles to protect your eyes from drill chips.
- Be sure to remove all drilling chips from the vehicle body to prevent corrosion.

7) Remove burrs around the drilled hole with a file and touch-up the edge of the hole to prevent corrosion.

Check	<input type="checkbox"/>
-------	--------------------------

B. INSTALLING THE REAR MUD-GUARD

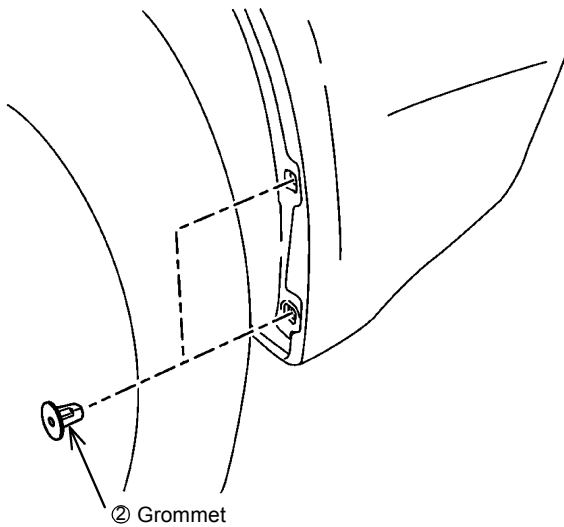

1) Insert two grommets ② into the existing holes at the inside of the rear wheelhouse as shown in the drawing.

2) Clean and degrease the rear mudguard mounting position using isopropyl alcohol or degreaser.

⚠ Caution

Never use organic solvent such as thinner, benzene, gasoline, etc.

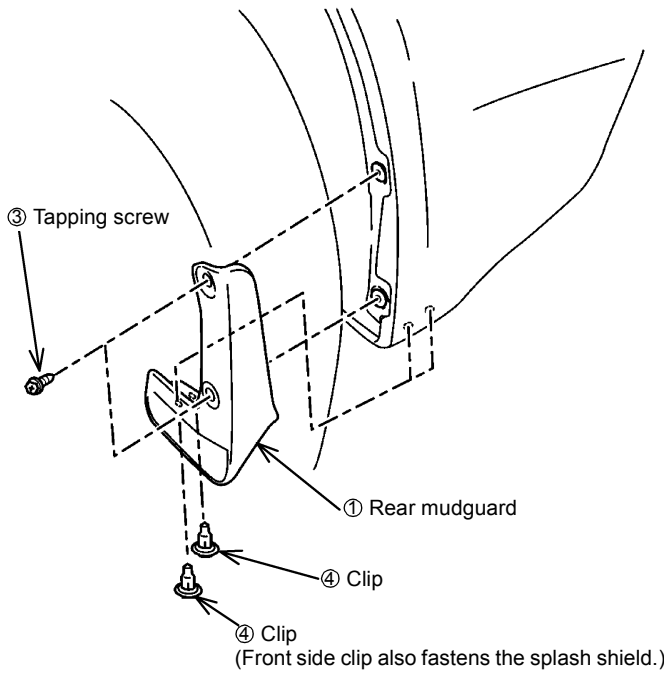

3) Fit the rear mudguard ① on the body and install the two clips ④ at the bottom of the mudguard. The front side clip should also fasten the splash shield.

4) Loosely tighten the tapping screws ③. Adjust the position of the rear mudguard ① so that there is no clearance between the mudguard ① and the body and then tighten the tapping screws ③ securely.

Check	<input type="checkbox"/>
-------	--------------------------

C. CHECKING AFTER INSTALLATION

- Check that the screws are tightened securely. Retighten as necessary.
- Check that there is no clearance between the rear mudguard and the body.

Check	<input type="checkbox"/>
-------	--------------------------

CARE AND HANDLING

- To clean the product, wipe with a soft material, such as sponge or chamois leather.
- Do not use any hard material for cleaning such as a scrubbing brush. It could scratch the surface.
- Do not use wax with compound. It could damage the surface.
- Take care to prevent contact with gasoline, kerosene, brake fluid, engine oil, grease, paint thinner, sulfuric acid (battery electrolyte) and wax remover that could cause discoloration, staining and cracking. Should any of them contact the surface, remove the substance immediately by wiping with a soft cloth or chamois leather moistened with a mild detergent, then wash the surface completely with water.