



# INSTALLATION INSTRUCTIONS

<b>Accessory</b> <b>17" ALUMINUM WHEEL</b> <b>P/N 08W17-T2A-100</b>	<b>Application</b> <b>2014 ACCORD</b> <b>2 AND 4-DOOR</b>	<b>Publications No.</b> <b>All 49929</b>
		<b>Issue Date</b> <b>AUG 2013</b>

## PARTS LIST

Aluminum wheel  
(The illustration may differ from the actual wheel.)



Wheel center cap  
(The illustration may differ from the actual center cap.)



Valve

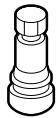

Wheel cleaning information  
(Give this information to your customer.)

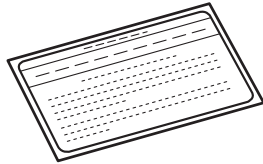

TPMS Information  
(For models not equipped with standard 17" wheels. Give this information to your customer.)

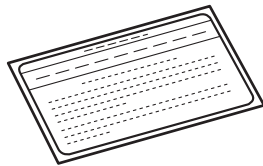

Tire pressure information label  
(May not be used.)



Supplemental information  
(May not be used.)

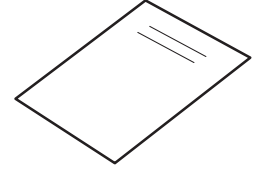

## TOOLS AND SUPPLIES REQUIRED

- Isopropyl alcohol
- Shop towel
- HDS/MVCI

## SPECIFICATIONS

**Models not equipped with standard 17" wheels:**

Rim size	17 x 7 1/2 J (inset 55)	
Tire size	215/55R17 94V	
Bolt hole PCD	114.3 (5 holes)	
Tire pressure	Front	225 kPa (2.25 kgf/cm <sup>2</sup> , 33 psi)
	Rear	225 kPa (2.25 kgf/cm <sup>2</sup> , 33 psi)

**Models equipped with standard 17" wheels:**

Refer to the owner's manual.

## INSTALLATION

**Customer Information:** The information in this installation instruction is intended for use only by skilled technicians who have the proper tools, equipment, and training to correctly and safely add equipment to your vehicle. These procedures should not be attempted by “do-it-yourselfers.”

### NOTE:

- This aluminum wheel is designed for use on a vehicle equipped with TPMS (Tire Pressure Monitoring System).
- The illustrations of the aluminum wheels are shown for reference purposes only.
- Install the correct size tire.
- Use a tire changer to install and remove the tires as described in the Operation Manual furnished with the tire changer. Do not use a tire lever to install and remove the tires as it may cause damage to the tire and aluminum wheel.
- The wheel nut torque is 108 N·m (80 lbf·ft).
- This kit should be installed only if the ambient air temperature is 60°F (15°C) or above.
- To allow the adhesive to cure, do not wash the vehicle for 24 hours. Please advise the customer.

### Models equipped with standard 17” wheels:

Discard the TPMS information, tire pressure information label and supplemental information in this kit.

- Be sure to give the wheel cleaning information to your customer.

### Perform steps 1 through 10 for models not equipped with standard 17” wheels.

1. Open the driver’s door. Using isopropyl alcohol on a shop towel, thoroughly clean the area where the tire pressure information label will attach. Remove the adhesive backing from the label, and attach it over the standard tire pressure information label as shown.

#### ACCESSORY TIRE PRESSURE INFORMATION LABEL

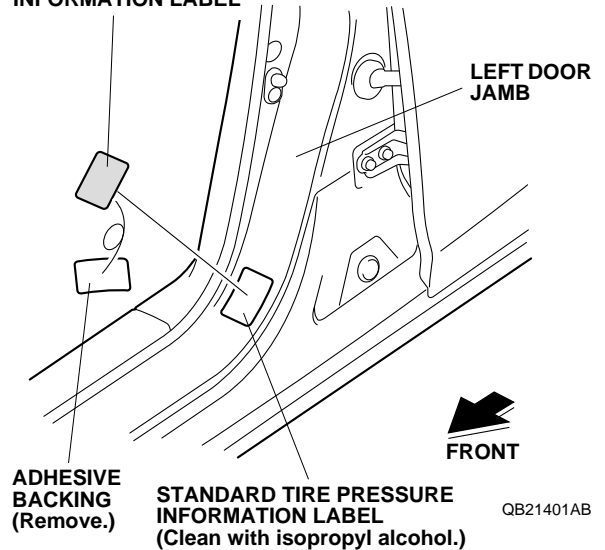

2. Attach the “Supplemental Information” page included in this kit into the owner’s manual. For the method of attaching the page, refer to “Important Information to Dealer” attached to the “Supplemental Information” page.

## Inch-up Tire Pressure Programming

- Connect the HDS tester to the OBD II data link connector, then turn the ignition switch to the on (II) position.

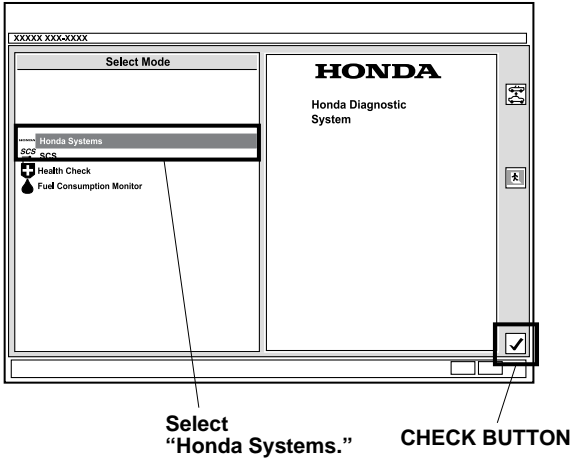

QA01801AH

- Start the HDS.
- Select **Honda Systems**, then click the check button.
- Select **ABS TCS VSA** and click the check button.

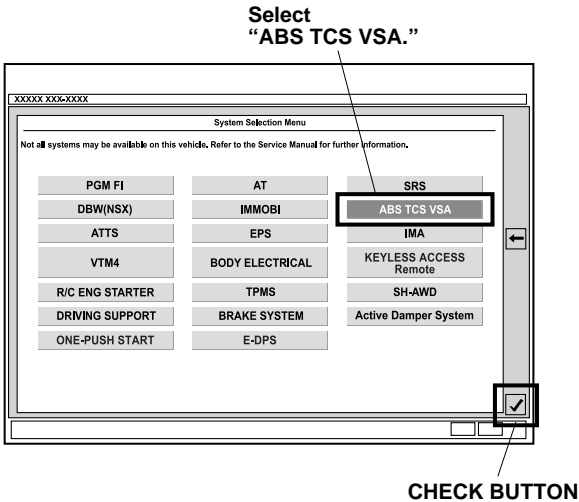

QA01802AH

- Select **Deflation Warning System** and click the check button.

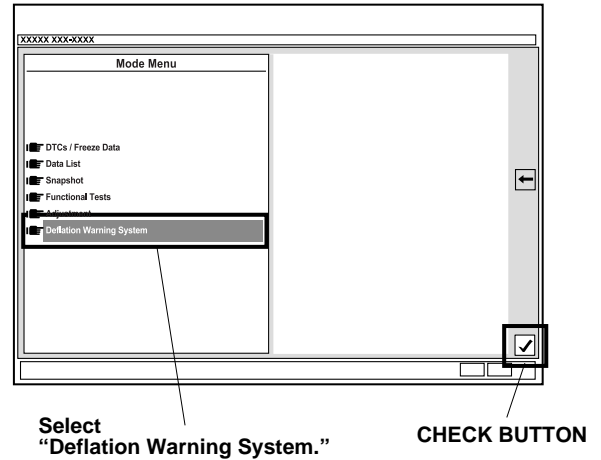

QA01803BH

- Select **17 Inch** and click the check button.

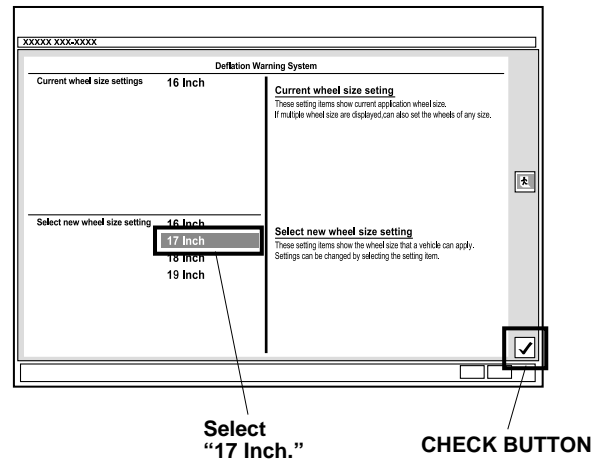

QB72001AB

- Disconnect the HDS.
- After finishing the work, write tire size, tire pressure, HDS version, dealer name, technician's signature and date in "Service History Page for Honda Accessory Alloy Wheels" page included in this kit.
  - Be sure to explain the contents of the "Supplemental Information" when delivering the vehicle to your customer.
  - Be sure to give the wheel cleaning information and TPMS information to your customer.

### **Deflation Warning System Threshold Rewriting**

- If the 16 inch wheels are to be installed back on the vehicle, you must change the threshold value with the HDS; refer to steps 3 to 9.
- For step 8, select **16 Inch** on the **Deflation Warning System**.