



Installation instructions

Audi A4 2008 ►

**Side sills,
for scope of delivery 8K0.071.685
Audi Genuine Accessories**

Edition 05.2012



Contents

1	General notes	1
2	Please read carefully before you begin!	2
2.1	Painting guideline for primed PUR-RIM components	2
2.2	Assembly adhesive/processing conditions/basic procedure	3
3	Parts overview	5
4	Sequence of operations	6
4.1	Preparations	6
4.2	Installing the side sills	6
4.3	Attaching the stone impact protective film	10
5	Appendices: Certificates, expert evaluations	12



1 General notes

Please read and take note of these WARNING, Caution and Note descriptions before carrying out maintenance or repair work.

 **WARNING**

Text with this symbol contains information concerning your safety and indicates potential accident and injury risks.

 **Caution**

Text with this symbol indicates the risk of damage to your vehicle.

 **Note**

Text with this symbol contains additional information.

- Text with this symbol describes a work instruction (guideline).
- Text with this symbol describes a condition to be maintained (fulfilled).
- ◆ Text with this symbol is used to show a list.

Special tools are required for assembly. Improper installation can cause damage to the vehicle or the add-on parts.

Audi AG shall not accept responsibility in the event of failure to comply with these assembly instructions.



2 Please read carefully before you begin!

2.1 Painting guideline for primed PUR-RIM components

Sanding: Wet P 600

Base paint:

Herberts quality:

Corresponds to: LMT 626 / ALD 626 UNI undercoat lacquer
LMT 845 / ALD 645 metallic undercoat lacquer
LPC 045 / ALD 045 pearl colour undercoat lacquer

Viscosity: 20 sec.
Applications: 2
Coat thickness: Approx. 20 µm
Airing time: 10 min.
Final airing time: 15 min.
Spray gun: Devilbiss GTI 1.4 mm

Clear paint:

Herberts quality:

Corresponds to: Two-component MS clear paint new
L2K 769 011 + 10% softener
2 : 1 + 10% thinner

Viscosity: 18 sec.
Applications: 2
Coat thickness: Approx. 50 µm
Airing time: 10 min.
Drying: Overnight at 20 °C
Spray gun: Devilbiss GTI 1.4 mm

⚠ Caution

Add-on components must always be painted in accordance with the „Audi Paintwork Guideline“.

Contrary to the guideline, add-on components must not be heat-dried but instead left to dry overnight at 20 °C — risk of deformation!



2.2 Assembly adhesive/processing conditions/basic procedure

Assembly adhesive suitable for add-on components made of:

- ◆ PUR-RIM¹⁾ "Side sills"

Processing conditions

- ◆ The assembly process should be completed 45 minutes after opening the assembly adhesive.
- ◆ The bonding surfaces on the body and the add-on component must be completely dry, clean and free from wax and oil or grease.
- ◆ Remove residual wax using benzine; benzine leaves a „greasing residue“, post-cleaning of bonding surfaces with isopropanol required!
- ◆ The bonding surfaces must be cleaned with isopropanol or the cleaner provided immediately prior to applying the assembly adhesive.
- ◆ Note the product instructions provided in the adhesive kit.

Basic procedure

- Use sandpaper to remove paint from and roughen the bonding surfaces of the component (remove paint residue).
- Remove sanding dust.
- The bonding surfaces on the body and the add-on component must be completely dry, clean and free from wax and oil or grease.
- Apply assembly adhesive, affix add-on component in its final position and attach firmly.

Caution

The entire assembly process must be completed within 45 minutes of opening the assembly adhesive — refer to the product instructions for the assembly adhesive reaction time.

¹⁾ In the case of ABS add-on components, the bonding surfaces must be carefully coated with primer after cleaning. Any impurities must be removed immediately with isopropanol or the cleaner provided. Drying time for primer: min. 30 minutes, max. 3 hours



- Use the putty knife provided, together with cotton cloth and isopropanol, to remove any adhesive residue.

⚠ WARNING

- **No vibrations to the adhesive for 12 hours - any required manoeuvring at max. walking speed.**
- **Wait at least 12 hours before removing the adhesive tape; protect the vehicle from water for 12 hours.**
- **The add-on components must not be subjected to any mechanical load for 24 hours — maximum speed 100 km/h.**
- **Do not wash the vehicle for 48 hours.**

The add-on components may work loose and detach when the vehicle is in motion if the adhesive reaction time is not observed — risk of accident.

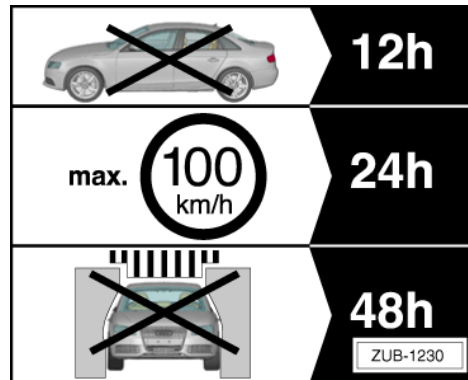



3 Parts overview

Parts required:

Assembly set 8K0.071.685

Comprising:

Units	Part number	Description
1	8K0.071.685	Sill covering set
1	8K0.071.737.B	Assembly package
1		Installation instructions

Contents of assembly package for side sill 8K0.071.737.B

Units	Description
4	Assembly aids
1	Stone guard film set
2	Assembly adhesive applicator tips

In addition, you will require:

- ◆ Removal lever -80 - 200-
- ◆ Removal wedge -3409-
- ◆ Standard fabric tape/masking tape
- ◆ Audi paint to match the vehicle's colour
- ◆ Cleaning solution D.009.401.04 (isopropanol)
- ◆ Benzine

Units	Part number	Description
1	00A.071.785	Adhesive kit

 **Note**

- ◆ One adhesive kit is enough to install one assembly set. Under favourable conditions, an additional assembly set can be bonded on.
- ◆ The tip of the tube must be cleaned or exchanged whenever there is a pause in the gluing process. Furthermore, the processing time for the assembly adhesive must be observed ⇒ „Assembly adhesive/processing conditions/basic procedure“ on page 3, as must the ⇒ product instructions included in the adhesive kit.



4 Sequence of operations

Vehicles with stone guard strips:

Special tools and workshop equipment required

- ◆ Body saw -V.A.G 1523 A-

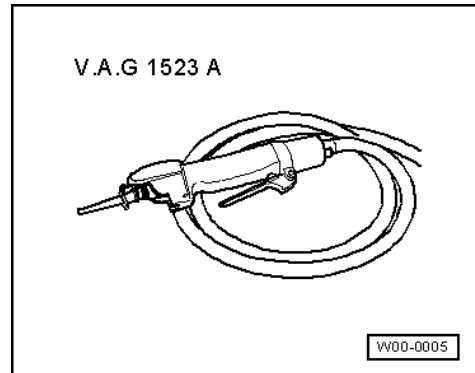

4.1 Preparations

Note

- ◆ *The add-on components are precision-manufactured and already primed. Nevertheless, they must be test-fitted in accordance with these assembly instructions prior to painting.*
- ◆ *When preparing to install the side sills, make sure that there is adequate clearance for installation when selecting the lifting platform/when raising the vehicle.*
- Prior to painting, fully cover the reinforcement parts -arrows- at the front and rear side sills with adhesive tape.
- Mask bonding surfaces.

Note

The assembly adhesive must contact the plastic surface of the reinforcement parts directly. A layer of paint prevents adhesion.

- Painting the side sills ⇒ „Painting guideline for primed PUR-RIM components“ on page 2 and ⇒ Audi Paintwork Guideline.

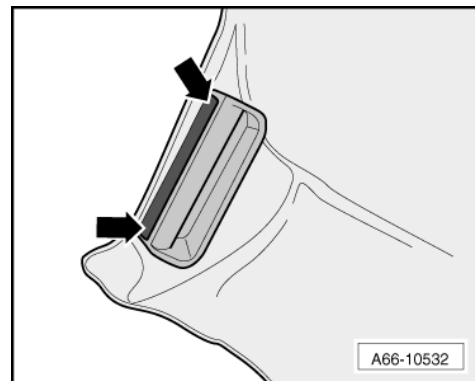

4.2 Installing the side sills

- Raise the vehicle on the lifting platform. When raising the vehicle, make sure that there is adequate clearance for installing the side sills and that the support plates on the lifting platform are placed as far inwards as possible.

Vehicles with stone guard strips:

Note

- ◆ *The guard strip is also attached to the side member with adhesive tape.*
- ◆ *Non-destructive removal is not possible.*



- Heat the bonding points with a hot air blower and gradually pull the guard strip -1- off the side member to the side.
- Pull the clips -2- off the side member.
- Where possible, cut off the welding studs -3- (9 per vehicle side) using the body saw -V.A.G 1523 A-.

! **Caution**

The welding studs must not be ground off using an axial grinder or angle grinder as this creates flying sparks!

i **Note**

The welding studs do not need to be ground off completely (flat). The „stumps“ are masked by the side sills.

Corrosion prevention measures

i **Note**

Corrosion damage caused by grinding and sawing is not covered by the vehicle warranty.

- In order to provide adequate protection against corrosion, apply the following products with a brush.
 - ◆ Single-component primer filler/surfacer LGF 008 001 42/A3
 - ◆ Two-component vario filler/surfacer, grey LGF 786 004 A3
 - ◆ Audi paint to match the vehicle's colour
 - ◆ Body cavity preserving agent D 330 KD2 A1

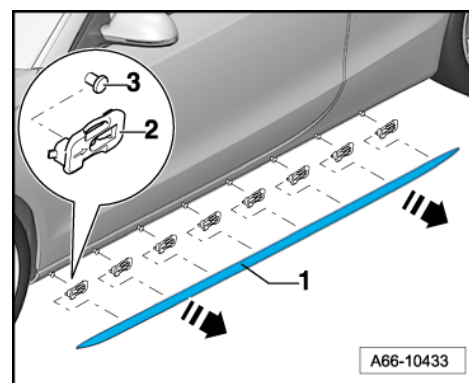



Continue for all vehicles:

- Release the outer nuts -1- from the front Cw trim by approx. two turns.
- Remove the bolt -2- from the rear Cw trim (re-use).

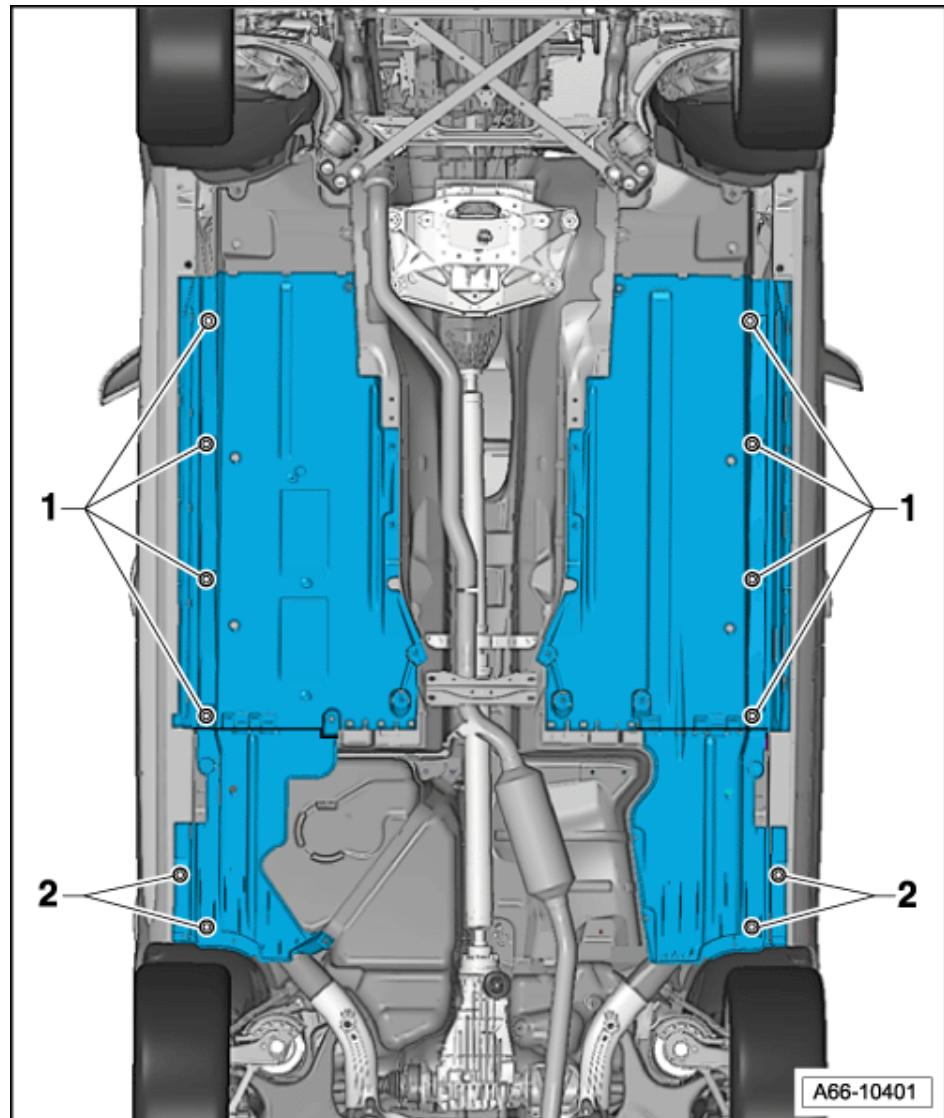

- Guide the lower edge of the side sill between the front and rear Cw trims and the body -arrows-.

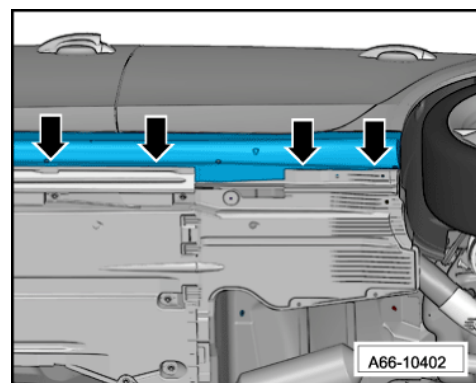



- Pull the side sill up slightly, align along the bottom edge of the door and the rear wheel housing and fix with adhesive tape. Pay particular attention to the crossover between the door's lower edge and the side wall -arrow 1- and the crossover to the rear wheel housing -arrow 3-.
- Attach the assembly aids -2-.
- Remove the side sill.

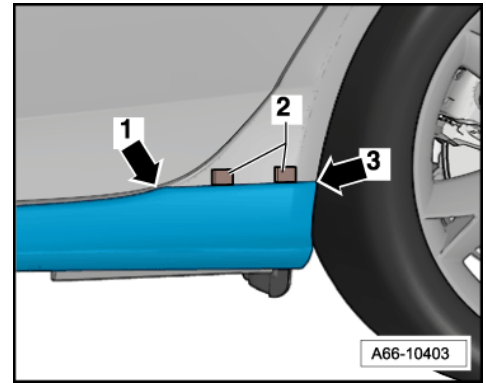

- Clean the side sill assembly surface: remove residual wax using benzine (benzine leaves a „greasing residue“), post-cleaning of bonding surfaces with isopropanol or the cleaner provided is therefore required!
- Roughen the adhesive groove -arrow-; remove any paint that may be present.
- Remove sanding dust.

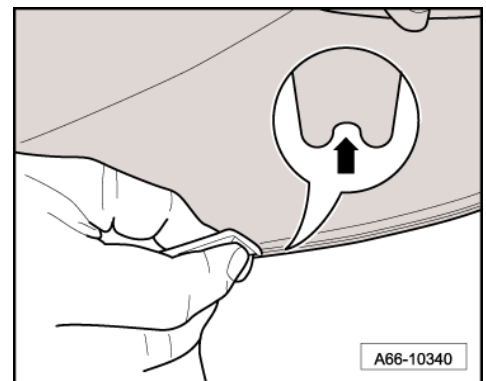

- Using isopropanol or the cleaning agent provided, thoroughly clean the adhesive groove, the filling areas of the reinforcement parts -arrows- at the front and rear side sills and the bonding surfaces on the vehicle.
- Use a clean assembly adhesive applicator tip: clean or exchange tip if necessary.
- Apply an even bead of adhesive approx. 5 mm Ø to the bonding surface (adhesive groove). The assembly adhesive must form an unbroken sealing surface after assembly. Observe the gluing guidelines ⇒ [Page 3](#).
- Completely fill the filling areas of the reinforcement parts -arrows- at the front and rear side sills with assembly adhesive (to the base) and also apply an adhesive bead approx. 5 mm in height.
- Secure the side sill in place with adhesive tape until the adhesive has cured.
- Screw the Cw trim into place.

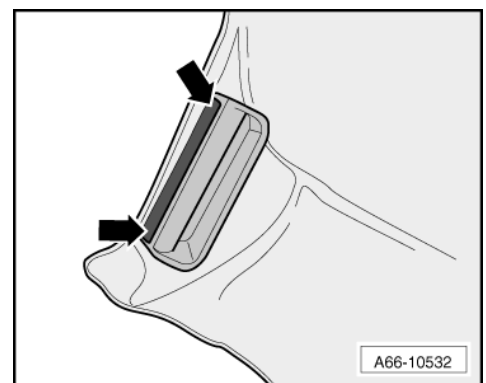

Tightening torques:

Component	Nm
Bolt for aerodynamic fairing	3.5
Nut for aerodynamic fairing	2



Secure the side sill in place to allow the assembly adhesive to cure, and remove any excess adhesive:

i Note

With a bulge build up, as shown in the upper half of the illustration, the component must be replaced and re-adhered.

- Use the putty knife provided, a cotton cloth and isopropanol or the cleaner provided to remove any adhesive residue.
- Ensure that the adhesive joint -arrows- between the side sill and the side wall is even; secure the side sill with additional adhesive tape if necessary.
- Use the putty knife provided to remove any adhesive that emerges. Do not overlook the areas under the adhesive tape.
- Make a final visual inspection to make sure that the adhesive joint is even and that all excessive adhesive has been removed.

i Note

The adhesive joint should be checked several times while the adhesive is curing and any adhesive that emerges should be removed.

- When the adhesive tape is removed (after a period of at least 12 hours), apply the stone guard film ⇒ „Attaching the stone impact protective film“ on page 10.

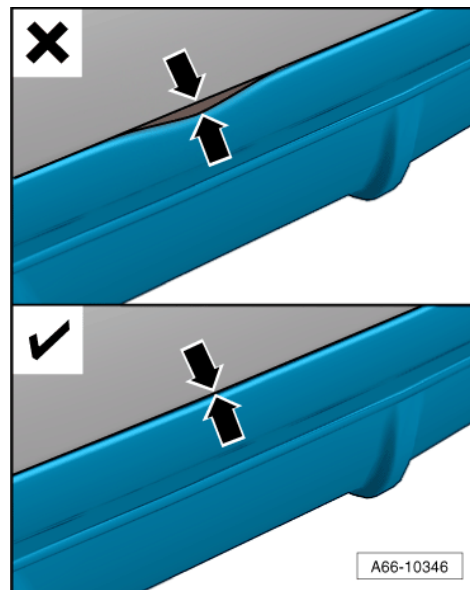

4.3 Attaching the stone impact protective film

! Caution

Experience has demonstrated that adhesion to painted surfaces is only possible after a minimum drying period (ventilation) of 24 hours.

Special tools and workshop equipment required

- ◆ Pump sprayer
- ◆ Squeegee
- or
- ◆ Standard ice scraper and cotton cloth
- ◆ Adhesive tape
- ◆ Washing-up liquid (household)
- Working temperature 1825 °C.
- No direct sunlight (the component must not absorb any heat from the sun).
- The film backing paper should remain in place until immediately prior to application.
- Wash the mounting surfaces thoroughly.



- Dry the mounting surfaces.
- The bonding surfaces on the vehicle must be free from dust and oil or grease.
- Degrease the assembly surfaces using isopropanol or the cleaning agent provided and cotton cloth.

i Note

Let the mounting surfaces air dry for five minutes.

- Fill the pump sprayer with water and add three drops of washing-up liquid per litre of water; mix well.
- Use the pump sprayer to spray the washing-up liquid solution onto the bonding surfaces on the vehicle.
- Spray fingers with the washing-up liquid solution and remove the film from the backing paper.
- Spray the bonding surfaces on the vehicle and film with the washing-up liquid solution, covering them fully.
- Position the film and align with the vehicle -arrows-.

i Note

- ◆ *The position of each film can be adjusted long after application.*
- ◆ *If the film will no longer move, remove it, re-spray with a liberal amount of washing-up liquid solution and reposition.*
- Starting from the centre of the film, use the squeegee to squeeze out the water and any air bubbles from underneath the film.
- Press on the film again and soak up the water using absorbent cloth or paper.
- If necessary, heat the film at the edges with a hair dryer or heat gun (max. 70 °C) and press onto the sill with the squeegee.
- At temperatures below 18 °C, the film, once stuck down, must be thoroughly heated through immediately after adhesion using a hair dryer or a heat gun (max. 70 °C).

! Caution

The film should not be subjected to (dry) road conditions until at least 6 hours after adhesion.

Optimal adhesion of the film to the surface is achieved after approx. 48 hours. During this time, the film should not be subjected to severe conditions such as splash water (wet roads) or car washes.

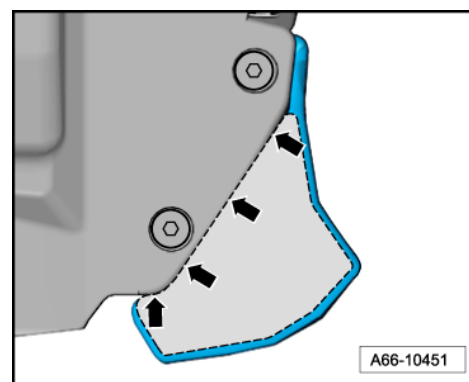



5 Appendices: Certificates, expert evaluations

The following are included after the installation instructions:

- ◆ the manufacturer's certificate of Audi AG
- ◆ Excerpt from the EC certification issued by the German Federal Motor Transport Authority
- ◆ Certificate from SGS-TÜV Saar GmbH (Technischer Überwachungs Verein/Technical testing organisation)

Note

Enclose any required country-specific documents from the appendix with the vehicle documents, so that these can be presented to authorised persons upon request.